

## DVT NP CNC

DEVICE FOR PREPARING PLASTIC SAMPLES



USED TO CUT SAMPLES USING CNC  
TECHNIQUE

## DVT NP CNC

### TECHNICAL SPECIFICATIONS

Used to prepare test samples from plastics, pipes, laminated products etc.

#### USED IN

- Plastic pipes
- Plastics
- Bio-medical

#### APPROXIMATE DIMENSIONS AND WEIGHT

- Width: 93 cm
- Depth: 79 cm
- Height: 90 cm
- Weight: 127.5 kg

#### RELEVANT STANDARDS

- ISO 6259-2 (Type 1)
- ISO 6259-3 (Type 3)
- ISO 13953 (Type 3, Type A1, Type A2)
- ASTM D 638-08 (Type 1, Type 2, Type 3, Type 5)

#### TECHNICAL INFORMATION

- Maximum cutting thickness: 60 mm.
- Possibility of defining dimensions in computer for different bowtie-shaped samples complying with the standards.
- The device won't start when the lid is open.
- Maximum cutting dimensions: 150x360 mm.
- Cutting tray dimensions: 400x530 mm.

#### OPTIONAL FEATURES

- Cutting capacity up to 80 mm in sample thickness.

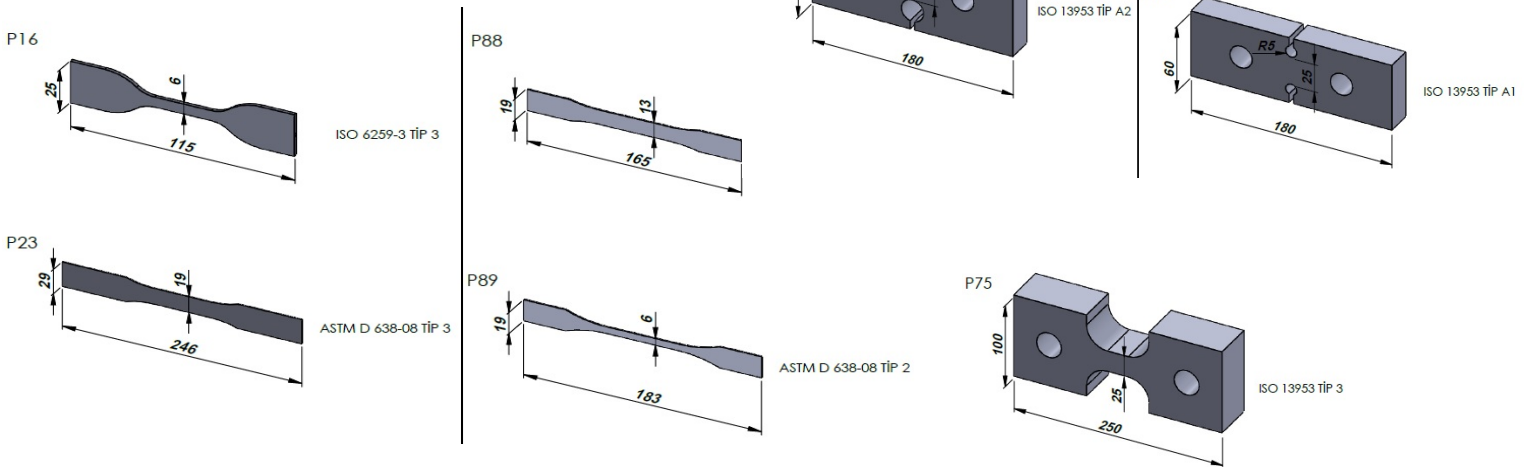

DVT DEVOTRANS reserves the right to make changes to the brochure. Photographed models may not be the latest ones.